



## Automated Parameter Studies in ENERGICO

EAPP-Parameter Study (v1.0) December 1, 2010

### Overview

This application note describes how the ENERGICO Simulation Package can be used to conduct automated parameter studies on key performance variables such as fuel/air ratio, fuel composition and inlet temperatures. This new feature in ENERGICO saves time and reduces calculation errors when performing such parameter studies on the Equivalent Reactor Network (ERN) that is created from a single CFD case in ENERGICO. An example is provided for a simple combustor where a fuel/air ratio variation is setup and performed to understand the impact on NO<sub>x</sub> emissions.

### Using Parameter Studies to Simulate Key Combustor Performance Tests

Experimental tests of gas turbine combustors are exceedingly expensive. Large engine tests can easily cost more than \$100,000US simply in terms of the fuel and other consumables used to perform the test. This does not include the manufacturing costs of combustor design, construction, installation, tear down or the labor involved in design and analysis of the results. Accurate combustion simulation has the ability to alleviate these expenses by replacing some experimental tests.

The ENERGICO Simulation Package's approach to using high fidelity ERNs constructed from CFD results has proven effective at predicting combustion performance for gaseous and liquid fired combustion devices such as gas turbines, boilers, etc. The ability to predict emissions and combustion performance at the condition represented in the CFD case is certainly valuable. The real power of ENERGICO lies in the ability to perform certain parameter variations with the ERN to generate the types of performance results that are typically obtained by experimental testing. These can be fuel-air ratio changes, inlet temperature or mass flow changes and fuel composition changes.

Accurately constructed ERNs have proven sufficiently robust over certain changes in parameters to provide accurate emissions and combustion performance simulations. It is true that when you make inlet changes in the ERN, the results deviate from the original CFD case from which the ERN was created. However, results have shown that if the flow field does not change substantially over the parameter change, then the ERN results are quite robust. This has proven true for modest changes in fuel-air ratio, inlet temperature, inlet mass flow rates or fuel composition. The changes in the specific reactor temperatures and reaction rates are accomplished when the energy equation is solved in the ERN. When you consider the fact that most ERNs take minutes to solve compared with several days for reacting flow CFD cases, there are significant savings in simulation time compared with creating several CFD cases to represent the parameter study.

## Options for Automated Parameter Studies with ENERGICO

Setting up a parameter study in ENERGICO is easy. The parameter variations can be specified through the Equivalent Reactor Network workflow tree, as shown in Figure 1. This allows the collection of a set of inlets and/or mass sources from the ERN, and allows the manipulation of associated properties in a series of parameter study runs.

Figure 1: Parameter study creation section of the Equivalent Reactor Network workflow tree

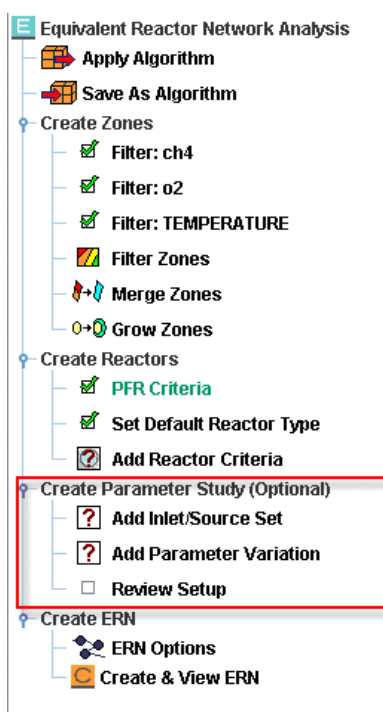

### Collecting Sets of Inlets and Mass Sources

The Add Inlet/Source Set item on the workflow tree launches a dialog that allows selection of which inlets and mass sources will be acted on for different parameter study variations. The definition of these inlet and source sets will be used in the manipulation of the varied properties in the parameter study.

The dialog for specifying an inlet/source set is shown in Figure 2. All of the inlets and mass sources that can be selected for inclusion in the set are listed in this dialog box. Selection criteria can be added to the list to filter out content of the list of inlet and mass sources.

Applying the changes creates a new entry in the workflow tree that is used in the creation of the parameter variation. In the example shown in Figure 2, we have selected inlets where the fuel (methane) mass fraction is greater than a minimum value, in order to identify the premixed fuel/air inlets and distinguish them from air inflows.

Figure 2: Inlet/Mass Source Set dialog box.

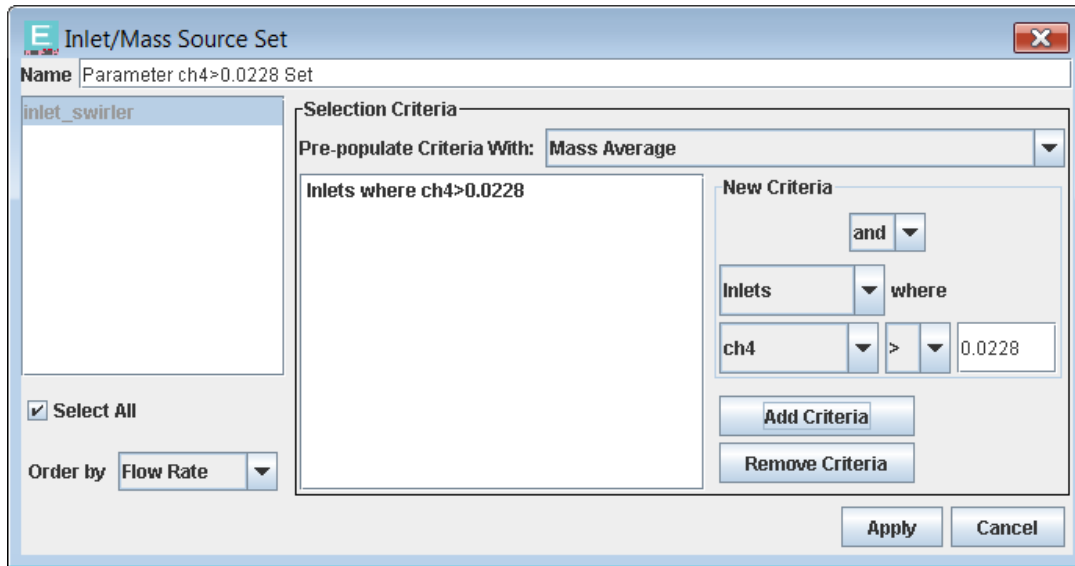

The Add Parameter Variation option in the workflow tree allows specifying one of four different kinds of parameter variation options. There are four different types of parameter studies that you can employ.

- Species composition variations for inlets and mass sources
- Flow ratio variations for inlets and mass sources
- Fuel-Air ratio variations
- Inlet mass flow rate or temperature variations

### Varying Inlet Species Compositions

The first option is to alter the species composition (in terms of mass fractions) of an inlet and source set, as shown in Figure 3.

The values in the **Start** and **End** field represent the mass-averaged values that will be used to change the content of the selected inlet and mass source set for the given number of parameter studies. The selected species is **CH4**. On the right side of the panel, the **N2** and **O2** species are identified as species whose mass fractions need to be modified proportionally to account for the change in the **Varied Species**, such that the sum of the mass fractions continues to be one for each case. The values can be populated based on a fixed increment or a fixed number of values. The **Set Values** button automatically calculates the values that will be used to alter the composition of the inlet and mass sources in the parameter study. For the inlet-composition parameter study, the total and relative inlet mass flow rates remain the same as for the nominal case.

Figure 3: Variation of species composition.

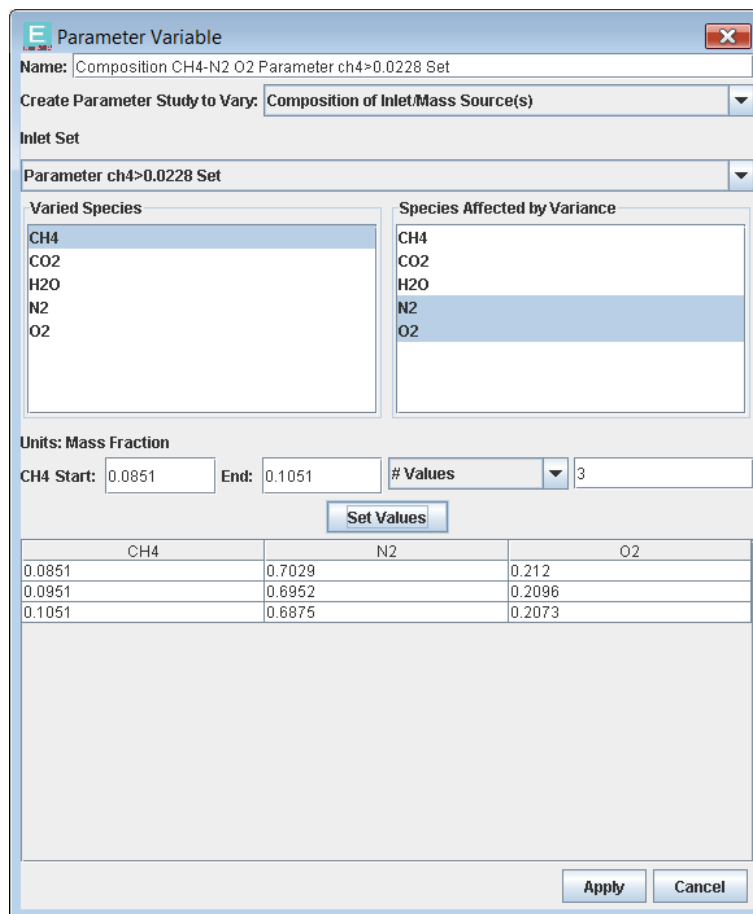

Parameter Variable

Name: Composition CH4-N2 O2 Parameter ch4>0.0228 Set

Create Parameter Study to Vary: Composition of Inlet/Mass Source(s)

Inlet Set

Parameter ch4>0.0228 Set

Varied Species		Species Affected by Variance	
CH4		CH4	
CO2		CO2	
H2O		H2O	
N2		N2	
O2		O2	

Units: Mass Fraction

CH4 Start: 0.0851 End: 0.1051 # Values: 3

Set Values

	CH4	N2	O2
	0.0851	0.7029	0.212
	0.0951	0.6952	0.2096
	0.1051	0.6875	0.2073

Apply Cancel

### Varying Flow Ratios

The second option for the variation of the inlet properties is to alter the flow rate ratios of two inlet/mass source sets, as shown in Figure 4. The selected inlet sets will pre-populate the content of the start ratio, and will automatically adjust the magnitude of the two inlet sets, while keeping the sum of flow rate constant. With all properties, the values in the table are mass averaged, and the resulting parameter study will adjust individual inlets and mass sources in a set in proportion to their initial value.

Figure 4: Varying flow ratios.

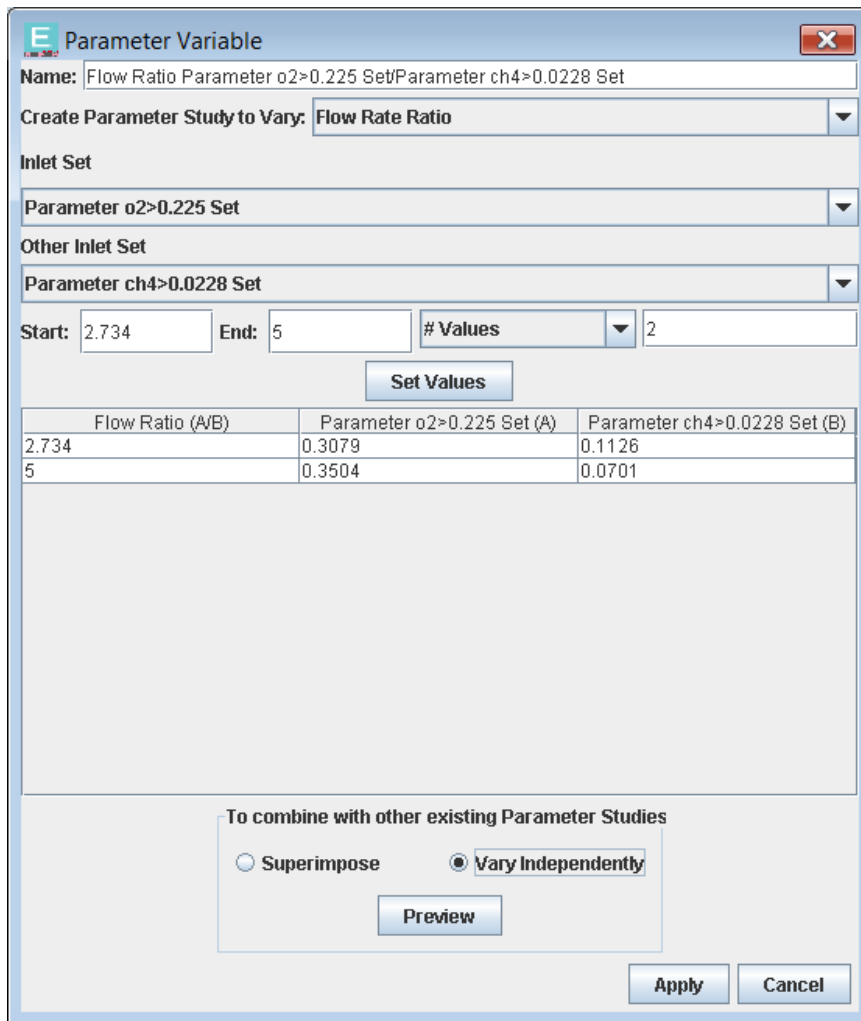

**Parameter Variable**

Name: Flow Ratio Parameter o2>0.225 Set/Parameter ch4>0.0228 Set

Create Parameter Study to Vary: Flow Rate Ratio

Inlet Set: Parameter o2>0.225 Set

Other Inlet Set: Parameter ch4>0.0228 Set

Start: 2.734 End: 5 # Values: 2

Set Values

Flow Ratio (A/B)	Parameter o2>0.225 Set (A)	Parameter ch4>0.0228 Set (B)
2.734	0.3079	0.1126
5	0.3504	0.0701

To combine with other existing Parameter Studies

Superimpose  Vary Independently

Preview

Apply Cancel

### Varying Fuel-to-Air Ratio

The third option for specifying an inlet/source parameter variation property is through fuel-to-air ratios, as shown in Figure 5. For this parameter study, you must select which species in the inlet correspond to the fuel and which species correspond to air. Then you need to select whether you want to fix the air flow and vary only the fuel flow or fix the fuel flow and vary only the air flow to achieve the desired fuel-air ratio variation.

Figure 5: Varying Fuel-Air Ratio

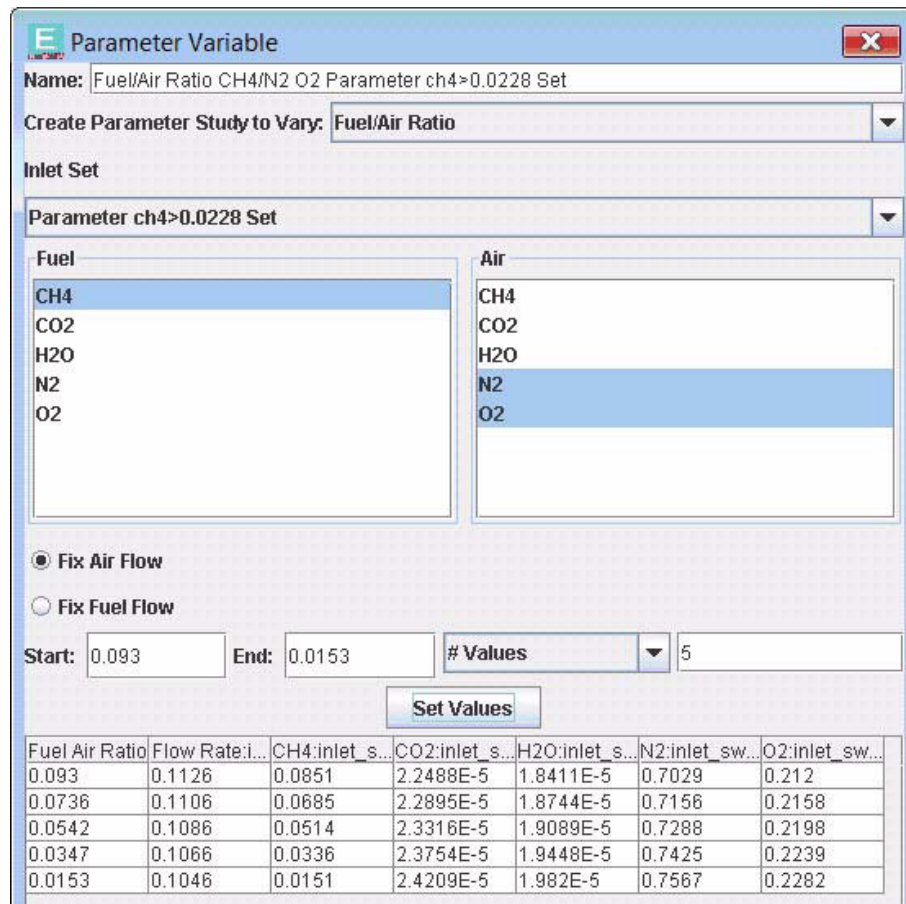

**Parameter Variable**

Name: Fuel/Air Ratio CH4/N2 O2 Parameter ch4>0.0228 Set

Create Parameter Study to Vary: Fuel/Air Ratio

Inlet Set: Parameter ch4>0.0228 Set

**Fuel**

- CH4
- CO2
- H2O
- N2
- O2

**Air**

- CH4
- CO2
- H2O
- N2
- O2

Fix Air Flow

Fix Fuel Flow

Start: 0.093    End: 0.0153    # Values: 5

**Set Values**

Fuel Air Ratio	Flow Rate:i...	CH4:inlet_s...	CO2:inlet_s...	H2O:inlet_s...	N2:inlet_sw...	O2:inlet_sw...
0.093	0.1126	0.0851	2.2488E-5	1.8411E-5	0.7029	0.212
0.0736	0.1106	0.0685	2.2895E-5	1.8744E-5	0.7156	0.2158
0.0542	0.1086	0.0514	2.3316E-5	1.9089E-5	0.7288	0.2198
0.0347	0.1066	0.0336	2.3754E-5	1.9448E-5	0.7425	0.2239
0.0153	0.1046	0.0151	2.4209E-5	1.982E-5	0.7567	0.2282

## Varying Inlet Properties

The last option for changing inlets is through the direct manipulation of a single property such as mass flow rate and temperature as shown in Figure 6. In the example shown, the mass flow rate is selected with units for the values of g/s. The parameter study generated will linearly vary the fuel mass flow rate from 0.1126 g/s to 0.01 g/s over four different runs, as indicated in the table below the **Set Values** button.

Figure 6: Varying Inlet Properties

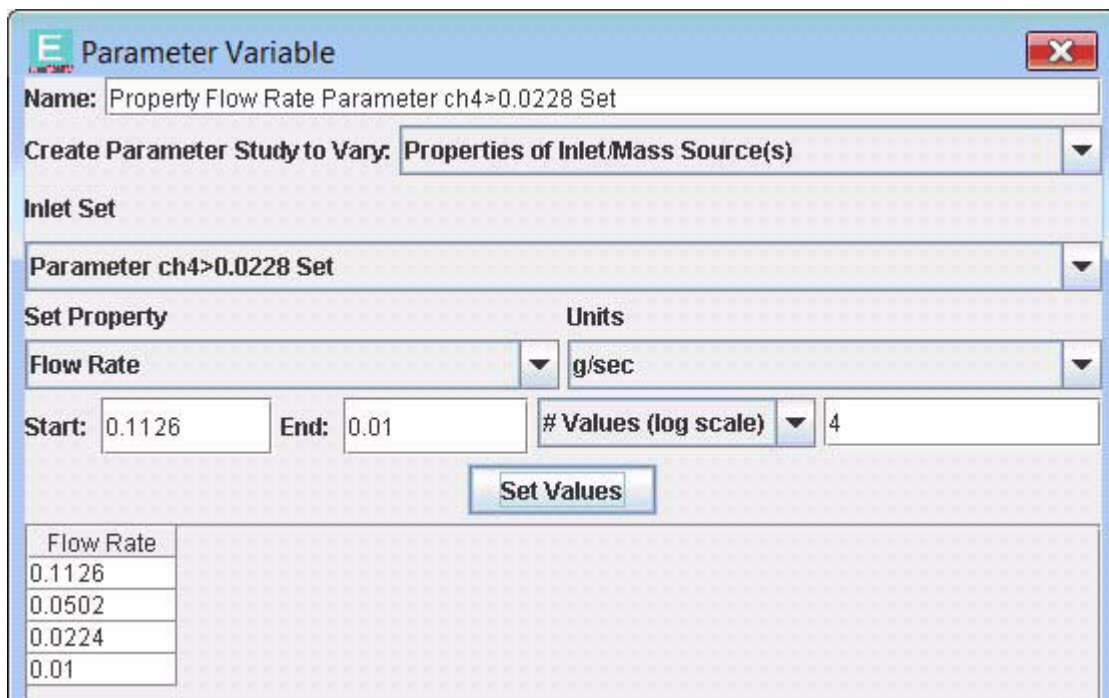

Flow Rate
0.1126
0.0502
0.0224
0.01

## Fuel/Air Ratio Parameter Study Example

In this example, an ERN is created for a single premixed fuel injector for an ultra-low NO<sub>x</sub> industrial gas turbine combustor (Drennan 2009). The CFD case from which the ERN was created is a full load case. ENERGICO was used to create an ERN that accurately predicted the NO<sub>x</sub> emissions at the condition of the CFD case. In this case, the ERN had only one inlet representing the fuel and air that were delivered into the test rig as shown in Figure 7.

Figure 7: ERN for industrial gas turbine premixed fuel injector

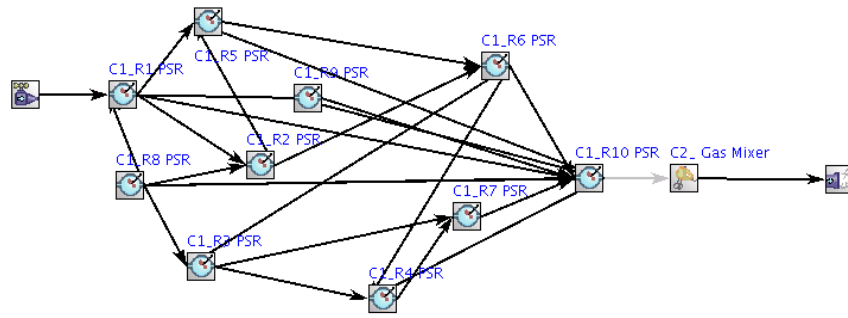

### Fuel/Air Parameter Study Results

A parameter study was created to simulate the affects increases in the fuel-air ratio would have on NOx production. This parameter study was created to simulate the conditions from an available set of experimental data. The parameter study option for fuel-air ratio was chosen for the study where fuel was increased while air flow rate was held constant.

The resulting increase in NOx normalized against the NOx of the CFD case is plotted against the exit temperature normalized against the exit temperature of the CFD case as shown in Figure 8. The ERN parameter study NOx results show excellent agreement with the experimental results. This shows that an ERN can be constructed from a single CFD case that provides good approximations of combustion performance when you make small changes in the operating conditions. Similar ERN parameter studies have been conducted with fuel composition for alternative or non-standard fuels with good success.

Figure 8: Results of parameter study on NOx variation with fuel-air ratio

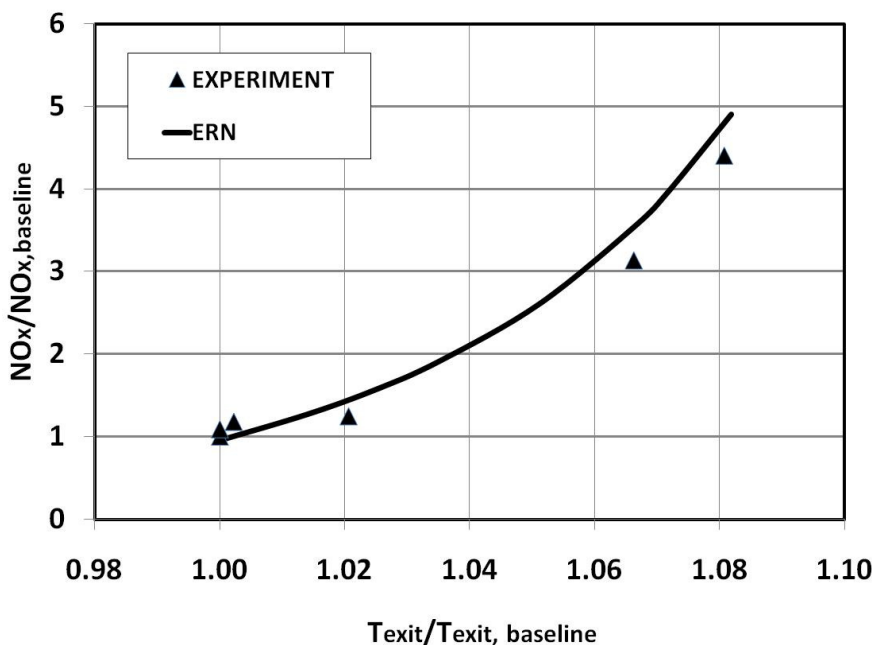

## Summary

This application note describes how ENERGICO can be used to develop perform automated parameter studies on key performance variables such as fuel/air ratio, fuel composition, mass flow rates and temperatures from a single CFD case. ENERGICO conducts the necessary mass flow and composition changes required to perform the parameter study that is chosen by the user and then runs the various ERN cases. Results such as emissions of NO<sub>x</sub>, CO and UHC can then be plotted against the parameter variation effectively simulating key combustor experimental test conditions.

## References

Drennan, S. A., et al, "Flow Field Derived Equivalent Reactor Networks for Accurate Chemistry Simulation in Gas Turbine Combustors," ASME Paper No. GT2009-59861, presented at the 2009 Turbo Expo Conference, Orlando, Florida, June 2009.

## About Reaction Design

Reaction Design helps transportation manufacturers and energy companies rapidly achieve their Clean Technology goals by automating the analysis of chemical processes via simulation and modeling solutions. Reaction Design is the exclusive developer and distributor of CHEMKIN, the *de facto* standard for modeling gas-phase and surface chemistry, providing engineers ultra-fast access to reliable answers that save time and money in the development process. Reaction Design's ENERGICO product brings accurate chemistry simulation to combustion systems using automated reactor network analysis. Reaction Design also offers the CHEMKIN-CFD software module, which brings detailed kinetics modeling to other engineering applications, such as Computational Fluid Dynamics (CFD) programs. Reaction Design's world-class engineers, chemists and programmers have expertise that spans multi-scale engineering from the molecule to the production plant. Reaction Design serves more than 350 customers in the commercial, government and academic markets.

Reaction Design can be found online at [www.reactiondesign.com](http://www.reactiondesign.com).

*CHEMKIN® and Reaction Design® are registered trademarks of Reaction Design. CHEMKIN-PRO, ENERGICO, and CHEMKIN-CFD are trademarks of Reaction Design.*